

## TECHNICAL DATA

### **BUS INTERFACE MODUL**

### **BIM M111/02, BIM M115/02**

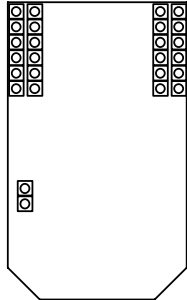

### **Ordering Information**

BIM M111: 5WG1 111 8AA02

BIM M115: 5WG1 115 8AA02

### **Features**

- *EIB* Bus Interface Module for piggyback-use on PCBs
  - MC68HC05B6 with mask programmed ROM, contains the *EIB* System Software
  - PEI <sup>\*)</sup> and Port A, PLM A and PLM B for applications available
  - Smallest *instabus* *EIB* Bus Access Unit
  - Operating Temperature Range:
    - BIM M111: - 5 to + 45 °C
    - BIM M115: - 25 to + 70 °C
  - EIB/KNX certified part
- <sup>\*)</sup> = *Peripheral External Interface*

### **DESCRIPTION**

The BIM M111 or the BIM M115 are members of Siemens *instabus* *EIB* BCU - family. They are especially designed as small modules for piggyback use and can be fitted directly into PCBs. The modules contain all functional parts of an *EIB* - BCU with the exception of the shift register for the serial synchronous interface. Additionally access to such microcontroller ports as Reset, PLMA, or Port A is possible. These ports are directly accessible by the user. Additional pins for the connection of an external programming button and a LED are available. For applications with the need of longer 'Bus Buffer Time' the BIM allows to connect an additional capacitance at bus voltage level.

*The reproduction, transmission or use of this document or its contents is not permitted without express written approval. All rights, including right created by patent grant or registration of a utility model or design, are reserved. Technical changes reserved.*

### Schematic Block Diagram

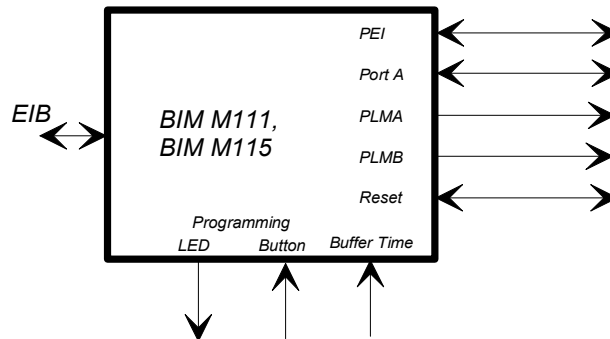

### Absolute Maximum Electrical Ratings

Rating	Symbol	Value	Units
Bus Voltage	V Bus	$\pm 35$	V
Microcontroller Input Voltage PEI, PLMA, PLMB, Reset, LED, Button	V...	GND - 0,5 to Vcc + 0,5	V
Microcontroller input or output current per Pin	I	see Motorola Technical Data MC68HC05B6	

### Features of the Controller

- CPU MC68HC05B6
- Operating Frequency 2,0 MHz (crystal frequency of 4,0 MHz)
- On-Chip RAM 176 Bytes ( 18 Bytes available for user )
- On-Chip EEPROM 256 Bytes (230 Bytes available for user)
- 8-Bit A/D-converter (5 channels available for user)
- 8-Bit pulse length modulator (PLM)
- Serial asynchronous communication interface
- Serial synchronous communication interface
- Watch dog

*The reproduction, transmission or use of this document or its contents is not permitted without express written approval. All rights, including right created by patent grant or registration of a utility model or design, are reserved. Technical changes reserved.*

### HARDWARE BLOCK DIAGRAM

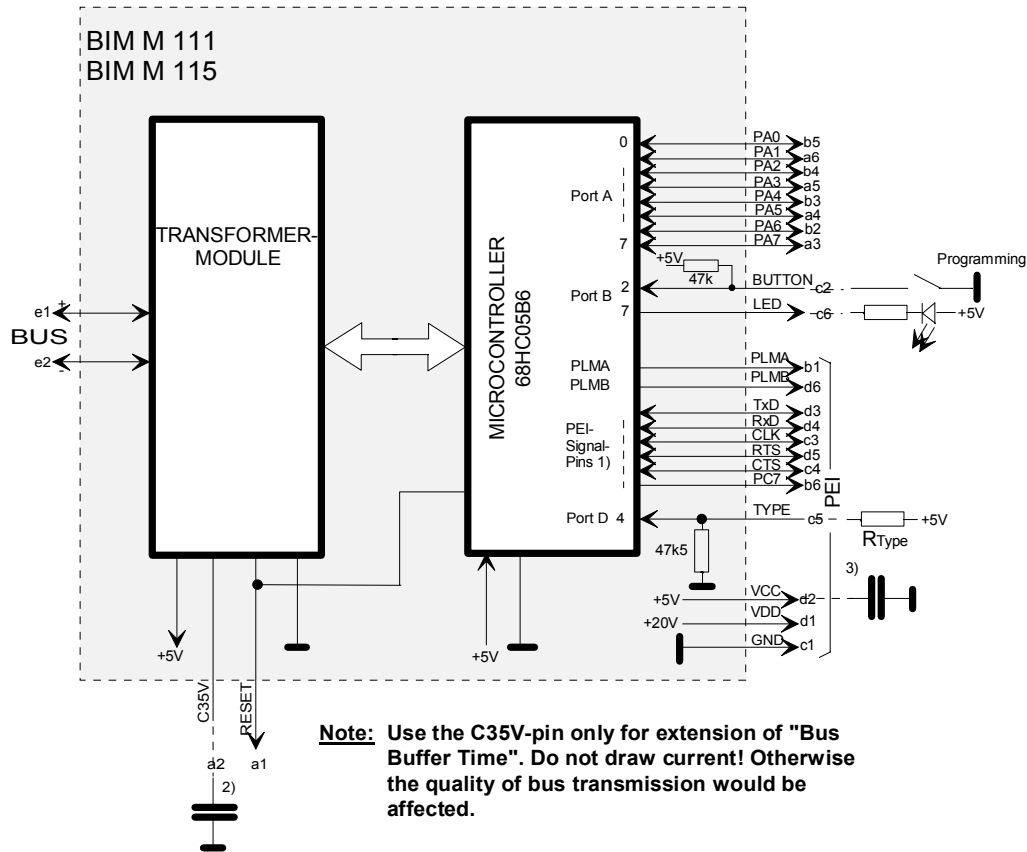

- 1) For detailed description see "PEI" - table.
- 2) Additional capacitance ( $V_c=35V$ ) for extended "Bus Buffer Time", e.g.  $100\mu F$ .
- 3) Additional capacitance ( $V_c=5V$ ) for extended "Bus Buffer Time", e.g.  $470\mu F$ .

### Memory Map

Address Range		Memory	Bytes
0000	001F	I/O, Register	32
0020	004F	ROM	48
0050	00BF	RAM	176
00C0	00FF	Stack	64
0100	0100	OPTR	1
0101	011F	EEPROM non protected	31
0120	01FF	EEPROM protected	224
0200	1FF1	ROM and unused areas	
1FF2	1FFF	Special functions	

The reproduction, transmission or use of this document or its contents is not permitted without express written approval. All rights, including right created by patent grant or registration of a utility model or design, are reserved. Technical changes reserved.

### PEI (Physical External Interface)

PEI – Pin – Assignment

	Pin Mnemonics	Power Supply	Serial Interface Async./sync.	I - Ports or A / D - Ports	Digital I / O - Ports	Remarks
a1	RESET				_RESET	In-/Output
a2	C35V					Buffer Capacitor
a3	PA7				PA7	Digital Input / Output
a4	PA5				PA5	Digital Input / Output
a5	PA3				PA3	Digital Input / Output
a6	PA1				PA1	Digital Input / Output
b1	PLMA				PLMB	Pulse-Length-Mod.
b2	PA6				PA6	Digital Input / Output
b3	PA4				PA4	Digital Input / Output
b4	PA2				PA2	Digital Input / Output
b5	PA0				PA0	Digital Input / Output
b6	PC7				PC7	Digital Output (Input / Output when PEI-Type17)
c1	GND	Ground				
c2	BUTTON				PB2	Digital Input
c3	CLK		SCLK	PD6	PC4	Clock •→
c4	CTS			PD3	PC6	Clear to Send •←
c5	TYPE			PD4		PEI - Type
c6	LED				PB7	Digital Output
d1	VDD	Vdd (20V)				2mA Current Limit.
d2	VCC	Vcc (5V)				
d3	TxD		TDO	PD5	PC3	Data •→
d4	RxD		RDI	PD7	PC2	Data •←
d5	RTS			PD2	PC5	Request to Send •→
d6	PLMB				PLMB	Pulse-Length-Mod.
e1	+ Bus					Bus Line
e2	- Bus					Bus Line

The reproduction, transmission or use of this document or its contents is not permitted without express written approval. All rights, including right created by patent grant or registration of a utility model or design, are reserved. Technical changes reserved.

### ELECTRICAL SPECIFICATION

See also KNX Specification, Version 1.0

Bus Interface Characteristics:

Characteristics	Symbol	Min	Max	Typical	Unit	Remarks
Operating Voltage	V <sub>Bus</sub>	21	30		V	
Current consumption	I <sub>Bus</sub>			4	mA	
Reset conditions	V <sub>cc</sub>	< 4,6			V	Reset generated by transceiver
BCU-Buffer-Time		TBD			ms	PEI-Load:50mW
Transmission Rate				9600	bit/s	

PEI DC-Characteristics:

Characteristics	Symbol	Min	Max	Typical	Unit	Remarks
Supply Output Voltage +5V	V <sub>CC</sub>	4.7	5.3		V	Max. 10mA
Supply Output Voltage +20V	V <sub>DD</sub>	18	20.5		V	load = 2mA V <sub>BUS</sub> - V <sub>DD</sub> > 1,5V V <sub>BUS</sub> = 21V ... 30V
Current Limitation	I <sub>DD</sub>	2	5		mA	
Data Output Voltage Port A, Port B, Port C	V <sub>OL</sub> V <sub>OH</sub>	V <sub>CC</sub> -0,8	0.4		V	I <sub>load</sub> =1,6mA I <sub>load</sub> =0,8mA
Data Output Voltage TDO, SCLK, PLMB	V <sub>OL</sub> V <sub>OH</sub>	V <sub>CC</sub> -0,8	0.4		V	I <sub>load</sub> =1,6mA I <sub>load</sub> =1,6mA
Data Output Voltage Reset	V <sub>OL</sub>		1,0		V	I <sub>load</sub> =1,6mA
Data Input Voltage Port A, Port B, Port C Reset, RDI	V <sub>IL</sub> V <sub>IH</sub>	0 0.7 V <sub>CC</sub>	0.2 V <sub>CC</sub> V <sub>CC</sub>		V	
Analog Input Voltage Range	V <sub>AIL</sub> V <sub>AIH</sub>	0	V <sub>CC</sub>		V	
I/O Ports Three-State-Leakage	I <sub>OZ</sub>		±10		µA	
Input Capacitance	C <sub>IN</sub>		50		pF	

The reproduction, transmission or use of this document or its contents is not permitted without express written approval. All rights, including right created by patent grant or registration of a utility model or design, are reserved. Technical changes reserved.

### Timing

The timing of Save, Reset, VCC and VDD which are depending on VBUS are shown in the following depiction:

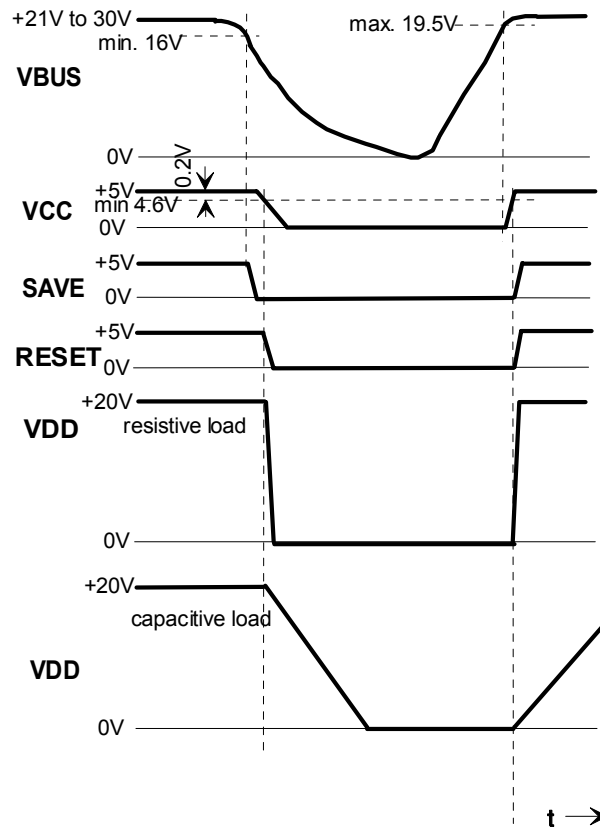

### Environmental Conditions

Rating	Symbol	Value	Unit	Remarks
Operation Temperature Range BIM M111	TA	- 5 to + 45	°C	no condensation
Operation Temperature Range BIM M115	TA	- 25 to + 70	°C	no condensation
Storage Temperature Range BIM M111	TSTG	- 25 to + 55	°C	
Storage Temperature Range BIM M115	TSTG	-25 to + 70	°C	
Relative Humidity		5 to 93	%	no condensation

The reproduction, transmission or use of this document or its contents is not permitted without express written approval. All rights, including right created by patent grant or registration of a utility model or design, are reserved. Technical changes reserved.

## SOFTWARE SPECIFICATION

See also KNX Specification, Version 1.0

### Application Hint

To avoid malfunctioning by EMI, it is recommended to shield the BIM. The connection for the electric screen is shown in the figure below.

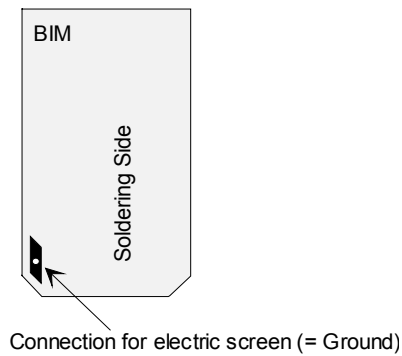

**The data contained herein are subject to change without notice. Siemens does not warrant for correctness or completeness of the documentation or that the products described are qualified for certification.**

*The reproduction, transmission or use of this document or its contents is not permitted without express written approval. All rights, including right created by patent grant or registration of a utility model or design, are reserved. Technical changes reserved.*

### MECHANICAL SPECIFICATION (BIM M111/02)

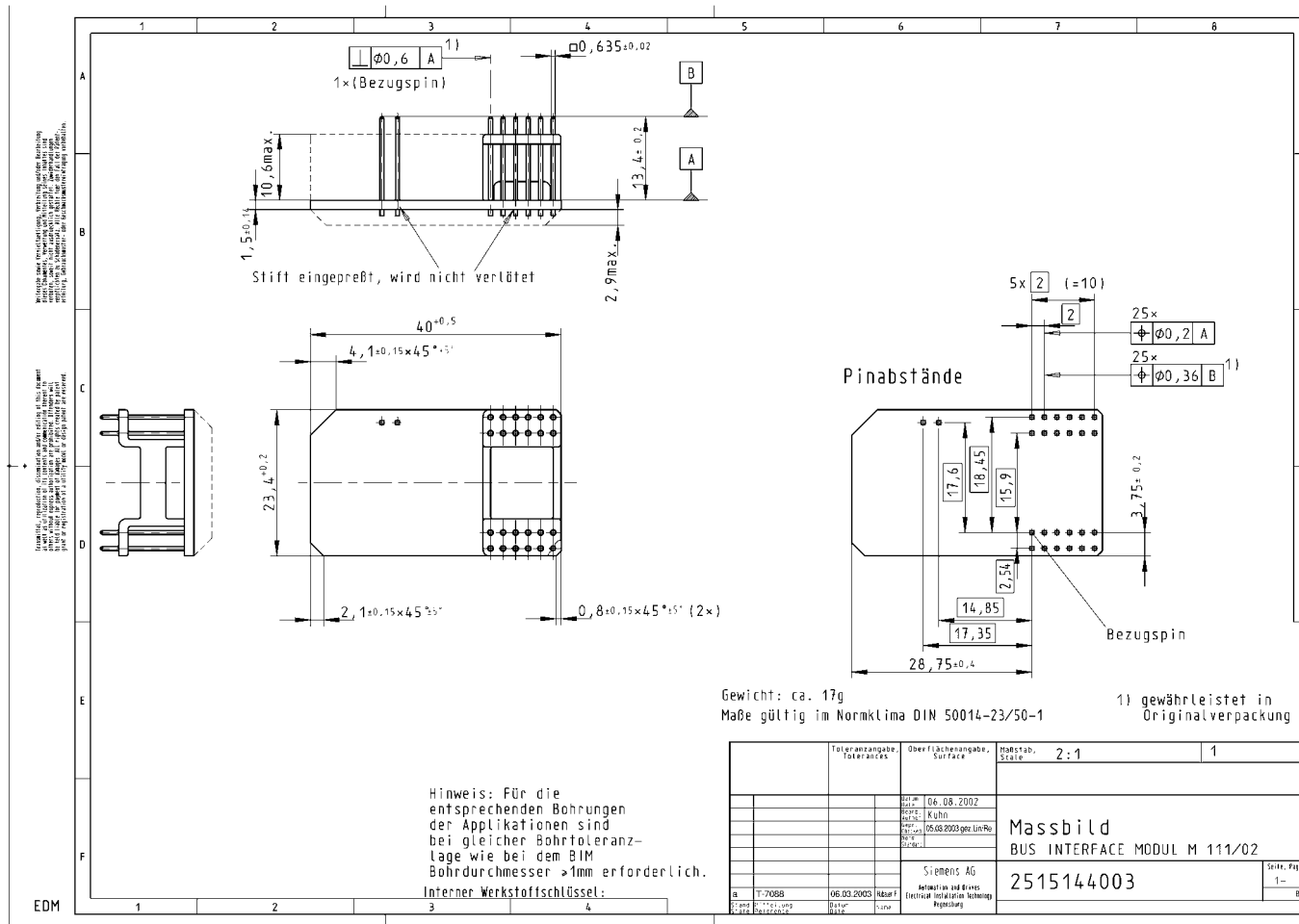

The mechanical specification of the BIM M115/02 is identical to BIM M111/02.

The reproduction, transmission or use of this document or its contents is not permitted without express written approval. All rights, including right created by patent grant or registration of a utility model or design, are reserved. Technical changes reserved.